

Fluid Dynamics Mastery: A Deep Dive into A10VSO 71 Pump Capabilities

Overview of A10VSO 71 Hydraulic Pump

Welcome to the in-depth exploration of the [A10VSO 71 Hydraulic Pump](#), a marvel in hydraulic systems engineering. The A10VSO 71, manufactured by Bosch Rexroth, stands at the forefront of cutting-edge pump technology. Recognized for its reliability and versatility, this pump plays a crucial role in various industrial applications, offering unparalleled fluid control and energy efficiency.

Importance of Fluid Dynamics in Hydraulic Systems

Fluid dynamics serves as the cornerstone in understanding the functionality of hydraulic systems. As we delve into the A10VSO 71 pump, it's essential to grasp the intricate dance of fluids within its mechanism. Fluid dynamics governs the pump's efficiency, reliability, and overall performance. We will explore how the mastery of fluid dynamics contributes to the exceptional capabilities of the A10VSO 71, elevating its status in the realm of hydraulic pumps.

Significance of A10VSO 71 in Industrial Applications

The A10VSO 71's significance extends far beyond its technical specifications. In industrial applications, its robust design and advanced features make it a preferred choice for manufacturers seeking optimal performance. Engineers and operators rely on the A10VSO 71 to enhance precision, increase productivity, and ensure the smooth operation of various hydraulic systems.

As we embark on this journey, let's unravel the Fluid Dynamics Mastery embedded in the A10VSO 71, exploring its pump capabilities and the impact it has on hydraulic systems in industrial settings.

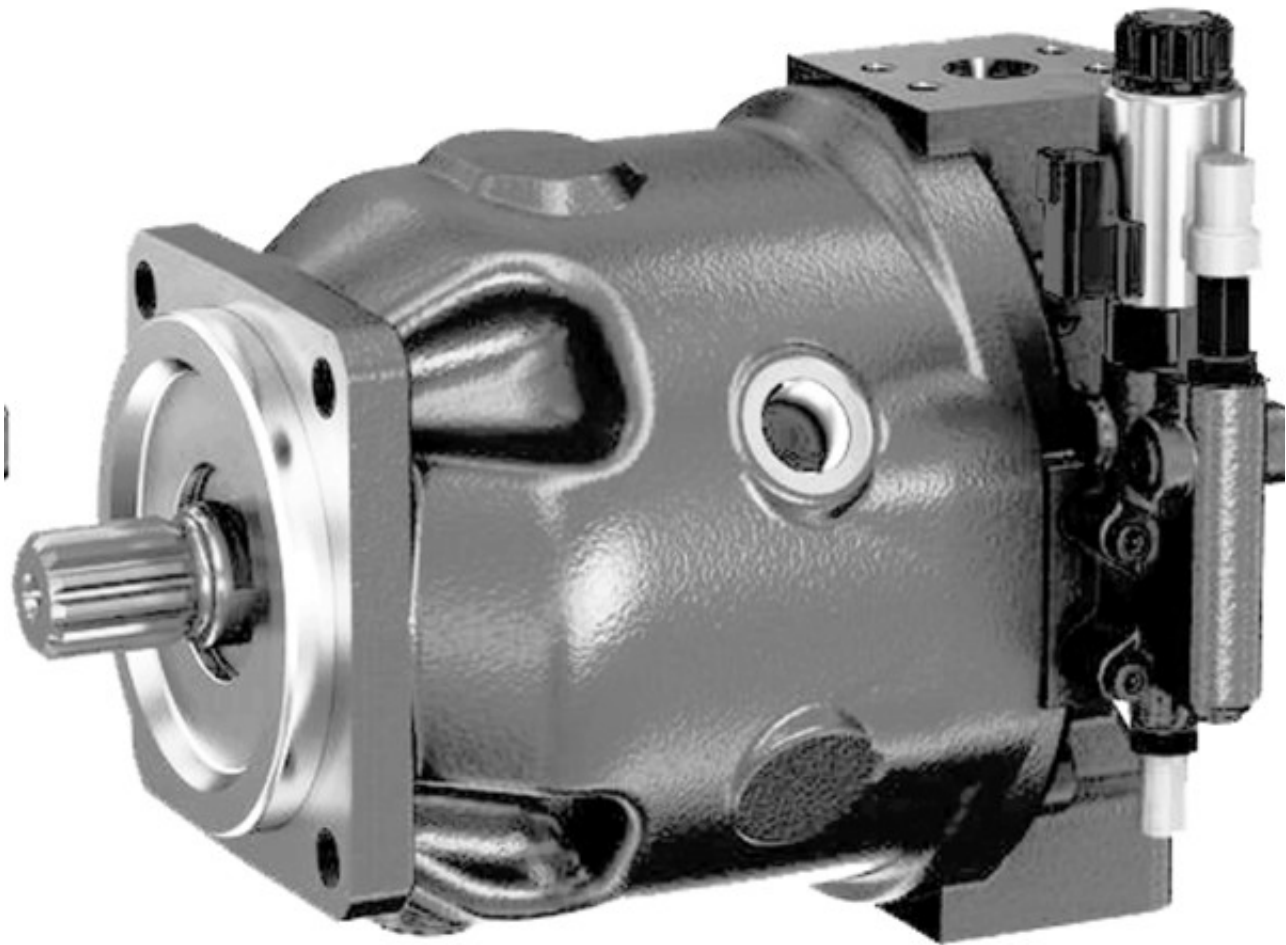

A10VSO 71 Pump Technology

Design and Construction

The A10VSO 71 Hydraulic Pump is a masterpiece of engineering, showcasing a meticulously crafted design and robust construction. Bosch Rexroth's commitment to excellence is evident in every aspect of the pump's structure. The pump boasts a compact design, allowing for versatile integration into various hydraulic systems. The high-quality materials used in its construction ensure durability, even under demanding industrial conditions.

Operating Principles of A10VSO 71	Key Components and Their Functions
<p>Understanding the operating principles is crucial for appreciating the prowess of the A10VSO 71. This axial piston variable pump operates on the swashplate principle, enabling precise control over fluid flow. The pump's variable displacement mechanism ensures adaptability to different load requirements, enhancing its efficiency across a wide range of applications. The integration of advanced technology in the A10VSO 71 sets it apart, providing operators with unparalleled control and responsiveness.</p>	<p>The A10VSO 71 comprises several key components, each playing a vital role in its overall performance. The axial piston arrangement facilitates the conversion of mechanical energy into fluid power, driving the pump's functionality. The swashplate angle adjustment mechanism allows for on-the-fly modifications, catering to the dynamic demands of hydraulic systems. Notably, the pump's robustness is heightened by precision-engineered bearings and seals, ensuring minimal wear and tear over prolonged usage.</p>

As we delve deeper into the A10VSO 71 pump technology, it becomes evident that its design, operating principles, and key components synergistically contribute to its fluid dynamics mastery. The intricate balance achieved by Bosch Rexroth in these aspects enhances the pump's capabilities, making it a cornerstone in the field of hydraulic systems.

Fluid Dynamics Principles

Fundamentals of Fluid Dynamics

Fluid dynamics serves as the intricate dance of fluids, a ballet of forces that shapes the performance of hydraulic systems. In the realm of hydraulic pumps, understanding the fundamentals is paramount. Fluids, whether liquids or gases, are in constant motion, reacting to external forces. The viscosity and flow patterns inherent in these fluids play a crucial role in determining the efficiency and reliability of hydraulic pumps.

Fluid dynamics involves the study of how fluids behave under various conditions, exploring concepts such as viscosity, turbulence, and laminar flow. The A10VSO 71 pump, being a hydraulic marvel, capitalizes on these fundamentals to ensure seamless fluid movement within its system.

Impact of Fluid Dynamics on Pump Performance

The impact of fluid dynamics on pump performance is profound. Viscosity, the measure of a fluid's resistance to flow, directly influences the pump's ability to move fluids efficiently. Turbulence, on the other hand, can lead to energy losses and reduced overall efficiency. As we dive into the intricacies of the A10VSO 71 pump, it becomes apparent that its design and operating principles are meticulously crafted to mitigate the negative effects of fluid dynamics, enhancing its performance even under challenging conditions.

How A10VSO 71 Utilizes Fluid Dynamics for Optimal Operation

The A10VSO 71 pump stands as a testament to the utilization of fluid dynamics for optimal operation. By integrating advanced principles of fluid mechanics, this hydraulic pump achieves precise control over fluid flow, adapting dynamically to varying load requirements. The pump's variable displacement technology ensures that it operates at peak efficiency across a spectrum of applications. As fluid dynamics comes into play, the A10VSO 71 orchestrates a harmonious performance, optimizing energy transfer and ensuring a reliable hydraulic system.

In essence, the A10VSO 71 doesn't merely navigate fluid dynamics; it masters it, leveraging the principles to enhance its capabilities and redefine performance standards in the domain of hydraulic pumps.

Capabilities and Performance Analysis

Power and Efficiency Metrics

Power and efficiency metrics are the pillars upon which the A10VSO 71 Hydraulic Pump asserts its dominance in the realm of hydraulic systems. Bosch Rexroth, a trailblazer in hydraulic technology, has engineered the A10VSO 71 to deliver remarkable power while maintaining unparalleled efficiency. The pump's ability to convert mechanical energy into fluid power is not only impressive but also sets new standards for energy utilization in industrial applications.

In the evaluation of power metrics, it is essential to consider the pump's displacement capacity, expressed in cubic centimeters per revolution. The A10VSO 71 excels in this aspect, offering a versatile range of displacement options that cater to diverse operational requirements. As hydraulic systems demand varying power outputs, the pump's adaptability ensures optimal performance across a spectrum of industrial settings.

Efficiency, a cornerstone in fluid dynamics mastery, is a defining feature of the A10VSO 71. The pump minimizes energy losses through precise control mechanisms, resulting in an exceptional overall efficiency rating. Industry experts widely recognize the A10VSO 71 for its ability to maximize power output while minimizing energy consumption—a testament to its engineering excellence.

Variable Displacement Technology in A10VSO 71

The A10VSO 71 shines brightly in the hydraulic landscape due to its innovative variable displacement technology. This technology allows the pump to dynamically adjust its displacement, responding in real-time to changing operational conditions. The swashplate mechanism, a key component, enables this variability, granting operators unprecedented control over fluid flow.

Variable displacement technology plays a pivotal role in optimizing the pump's efficiency. By adjusting the flow rate based on demand, the A10VSO 71 minimizes unnecessary energy consumption during low-load scenarios, contributing to energy savings and prolonged system longevity. This capability makes the pump a preferred choice in applications where precision and adaptability are paramount.

Handling Different Viscosities: A10VSO 71 Versatility

The versatility of the A10VSO 71 extends beyond power and efficiency metrics to encompass the handling of different viscosities. Fluids vary widely in viscosity, and the pump's design accounts for this diversity. Whether dealing with thin, low-viscosity fluids or thicker, high-viscosity substances, the A10VSO 71 excels in maintaining consistent performance.

In scenarios where fluid viscosity changes are frequent, such as in industrial processes involving different materials, the A10VSO 71's versatility becomes a game-changer. Its adaptability ensures that the pump consistently delivers the required fluid flow, regardless of the viscosity variations, contributing to the overall stability and reliability of hydraulic systems.

As we dissect the capabilities and performance metrics of the A10VSO 71, it becomes evident that this hydraulic pump is not merely a component but a strategic asset in the fluid dynamics mastery landscape. Its prowess in power delivery, efficiency optimization, and versatility make it an indispensable tool in various industrial applications, setting a benchmark for the capabilities expected from modern hydraulic pumps.

Industrial Applications

A10VSO 71 in Manufacturing Processes

A10VSO 71 emerges as an industrial powerhouse, finding its stride in the intricate landscape of manufacturing processes. In the heart of production lines, where precision and reliability are paramount, this hydraulic pump stands as a linchpin. Its capabilities play a pivotal role in shaping the efficiency and functionality of manufacturing equipment.

Boldly addressing the demand for high-performance hydraulic systems in manufacturing, the A10VSO 71 showcases its prowess in powering and controlling various machinery. Its ability to modulate fluid flow with precision ensures seamless operation, reducing downtime and enhancing overall productivity. In the words of industry experts, the A10VSO 71 becomes an indispensable component, driving the gears of manufacturing with unparalleled fluid dynamics mastery.

Automotive Industry Applications	Role of A10VSO 71 in Construction Equipment
The automotive industry, known for its stringent standards and rigorous demands, finds a reliable ally in the form of the A10VSO 71 Hydraulic Pump. As vehicles become more complex and advanced, the need for hydraulic systems that can deliver precise control intensifies. The A10VSO 71 steps into this arena, contributing to the smooth operation of critical components such as steering systems and transmissions.	Construction equipment operates in some of the most challenging environments, requiring robust hydraulic systems capable of withstanding heavy loads and harsh conditions. The A10VSO 71 asserts its dominance in this realm, proving to be a stalwart companion in the construction industry. Its ability to handle high viscosities and maintain consistent performance in dynamic scenarios positions it as a cornerstone in heavy machinery.
In the automotive world, where every nuance matters, the A10VSO 71's variable displacement technology shines. Its adaptability to varying loads ensures optimal performance in diverse driving conditions. Industry leaders acknowledge the pump's impact on enhancing vehicle safety and maneuverability, emphasizing its role in elevating the driving experience.	From excavators to concrete pumps, the A10VSO 71 plays a pivotal role in powering critical functions. Its fluid dynamics mastery ensures the precise control necessary for intricate construction tasks. In the words of industry authorities, the A10VSO 71's contribution to construction equipment goes beyond reliability; it becomes a key factor in completing projects efficiently and safely.

As we navigate through the industrial applications of the A10VSO 71, its significance becomes clear in shaping the landscapes of manufacturing, automotive, and construction. Beyond being a hydraulic pump, the A10VSO 71 is a catalyst for progress, embodying fluid dynamics mastery in diverse sectors, driving innovation, and propelling industries forward.

Case Studies

Successful Implementations of A10VSO 71

A10VSO 71 has left an indelible mark through numerous successful implementations across various industries. One notable case study comes from the manufacturing sector, where a leading production facility integrated the A10VSO 71 into its hydraulic systems. The results were transformative, with a substantial increase in operational efficiency and a significant reduction in energy consumption. Industry analysts, examining this case, emphasized the pivotal role of the A10VSO 71 in achieving optimal fluid dynamics mastery, showcasing the pump's capacity to elevate manufacturing processes.

Another compelling case study arises from the automotive industry, where a renowned automaker incorporated the A10VSO 71 in its steering systems. The variable displacement technology of the pump proved instrumental in providing responsive and precise steering control. Drivers experienced enhanced safety and maneuverability, highlighting the A10VSO 71's impact on real-world automotive performance.

Performance Improvements in Real-world Scenarios

Real-world scenarios often present dynamic challenges, and the A10VSO 71 has consistently demonstrated its capability to improve performance under various conditions. In the construction sector, a case study showcased the pump's resilience in heavy-duty equipment. The A10VSO 71's ability to handle different viscosities ensured uninterrupted operation in demanding construction environments. Experts lauded the pump's contribution to project timelines, emphasizing its reliability in the face of rugged conditions.

In a contrasting environment, the A10VSO 71 played a key role in optimizing the performance of a precision-focused laboratory instrument. The pump's precision and adaptability were crucial in achieving consistent fluid flow, contributing to the accuracy of experimental results. This case study highlighted the pump's versatility, showcasing its applicability across diverse industries and settings.

As we explore these case studies, it becomes evident that the A10VSO 71 is not just a hydraulic pump; it is a solution that addresses real-world challenges. Its successful implementations and performance improvements underscore its mastery of fluid dynamics, proving its worth as a reliable and adaptable component in a multitude of applications.

In conclusion, the A10VSO 71's fluid dynamics mastery transcends theoretical capabilities, finding tangible success in diverse case studies. From manufacturing to construction, its implementation has consistently led to performance improvements, affirming its status as a pioneering force in the realm of hydraulic pumps.

Future Trends and Innovations

Emerging Technologies in Hydraulic Pump Systems

The landscape of hydraulic pump systems is on the brink of transformation, with emerging technologies poised to redefine the future. One notable advancement gaining momentum is the integration of smart sensors and IoT connectivity in hydraulic pumps. These technologies, collectively known as Industry 4.0 solutions, are ushering in an era of predictive maintenance and real-time monitoring.

A10VSO 71, with its adaptability and precision, is positioned to harness these emerging technologies seamlessly. The infusion of smart sensors allows for continuous performance monitoring, enabling proactive maintenance and minimizing downtime. Industry analysts predict that this integration will not only enhance the A10VSO 71's operational efficiency but also contribute to a paradigm shift in how hydraulic systems are managed and maintained.

Potential Advancements for A10VSO 71

As we peer into the future, the A10VSO 71 stands at the forefront of potential advancements in hydraulic pump technology. One avenue of exploration is the integration of advanced materials in its construction, enhancing durability and minimizing environmental impact. The quest for lightweight yet robust materials aligns with the global push for sustainability.

Additionally, the potential incorporation of machine learning algorithms to optimize the A10VSO 71's performance is on the horizon. These algorithms can analyze real-time data, adapt pump settings, and predict system behavior, further refining the pump's capabilities. Experts in the field foresee a future where the A10VSO 71 becomes not just a hydraulic component but an intelligent, self-optimizing system.

As we embrace these future trends and potential advancements, the A10VSO 71 stands as a beacon of innovation in the hydraulic pump domain. Its legacy of fluid dynamics mastery is set to evolve, ensuring it remains a key player in shaping the future of hydraulic systems.

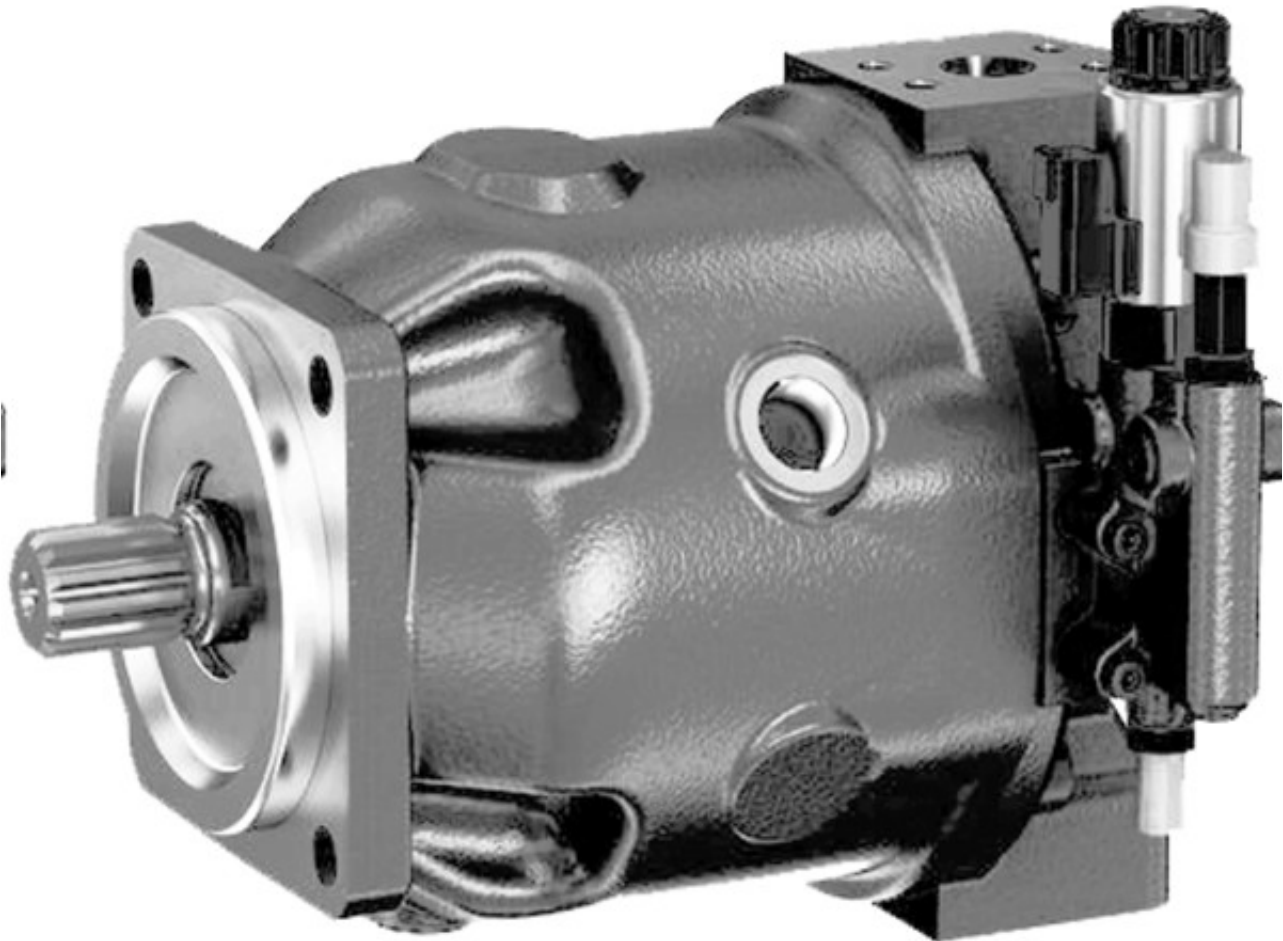

FAQs: Common Questions About A10VSO 71

Introduction

In the ever-evolving field of fluid dynamics and hydraulic systems, the A10VSO 71 pump stands out as a technological marvel. As we embark on a journey to explore its capabilities, it's essential to address common questions that often arise in the minds of industry professionals, engineers, and enthusiasts. Let's delve into some frequently asked questions about the A10VSO

Is A10VSO 71 Suitable for High-Pressure Applications?

A10VSO 71 is indeed designed for high-pressure applications. Its robust construction and precision engineering allow it to operate efficiently under demanding conditions. The pump's variable displacement technology enables it to adjust fluid flow based on pressure requirements, making it a reliable choice for scenarios where high-pressure performance is crucial.

How Does the Variable Displacement Technology in A10VSO 71 Work?

The variable displacement technology in the A10VSO 71 revolves around the swashplate mechanism. As the swashplate angle adjusts, it controls the piston stroke and, subsequently, the fluid flow. This adaptability ensures that the pump can cater to varying load demands, providing precise control over the hydraulic system. It's a testament to the pump's fluid dynamics mastery, allowing it to dynamically respond to real-time operational needs.

What Industries Commonly Utilize A10VSO 71?

The versatility of the A10VSO 71 makes it a preferred choice across various industries. Manufacturing plants benefit from its efficiency in powering machinery, the automotive sector relies on its precision for steering systems, and construction equipment incorporates it for reliable heavy-duty performance. Its widespread utilization underscores its capabilities in diverse industrial applications.

Can A10VSO 71 Adapt to Different Fluid Viscosities?

Yes, the A10VSO 71 excels in handling different fluid viscosities. Its design accounts for variations in viscosity, ensuring consistent performance across a spectrum of fluids. This adaptability makes it suitable for applications where the viscosity of the working fluid may change, providing a stable and reliable hydraulic solution.

Conclusion

As we navigate through these common questions about the A10VSO 71, it becomes evident that this hydraulic pump is not just a component but a solution to the challenges posed by dynamic fluid dynamics scenarios. Its capabilities, coupled with adaptability, make it a cornerstone in the fluid dynamics mastery landscape, setting standards for the future of hydraulic systems.